



The MRL are long-range LED Range Lights, especially designed to mark port approaching and entrance channels, rivers and straight lanes in bays. They are commonly used in traditional leading stations of two lights, in both day and night modes.

The navigator can move forward by the centre of a narrow channel when the two lights are aligned, separating them when the vessel strays from one side; this provides information on his position outside the leading line. When these lights are synchronized, they are much more conspicuous to distinguish them in locations with strong background lighting.

The MRL light produces an unidirectional beam with a horizontal divergence from 1.7° to 4.3°. Its luminous source, consisting of high-power LEDs of 100,000 hours average life, makes it a maintenance-free beacon.

Designed according to IALA Recommendations.

FEATURES

- ✓ State-of-the-art LED technology.
- ✓ Day range up to 4 nm.
- ✓ Nominal night range up to 21 nm (T=0.74).
- ✓ Maximum total LED power: 15W.
- ✓ Horizontal divergence up to 4.3° (50%Io).
- ✓ High-accuracy optical system, stabilised against vibrations.
- ✓ Enclosure made from marine aluminium with outer polyurethane finishing.
- ✓ Circular, high-resistance glass lens cover.
- ✓ Average operation lifetime over 25 years.
- ✓ 100% humidity resistant.
- ✓ Double RS-232 serial port for setting adjustments by PC and remote monitoring system.
- ✓ Maintenance free.



LED RANGE LIGHT MRL



Specifications subject to change without previous notice.

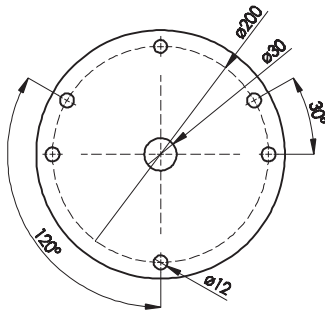
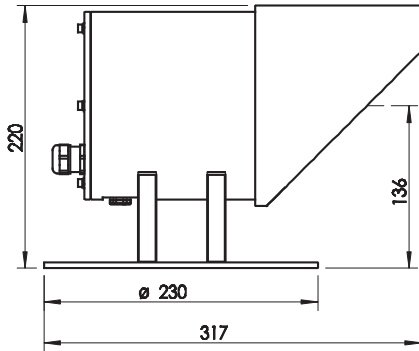

Options

- Programmable by IR programmer.
- Synchronization by cable or GPS receiver.
- Remote monitoring module via GSM, radio or satellite.
- RS-485 MODBUS serial port.
- Other divergences available under request.

Optical system

Light source:	High-intensity LED diodes.
Lens:	Collimator, a lens for each LED.
Day range:	Up to 4 nm.
Nominal night range:	Up to 21 nm (T=0.74).
Horizontal divergence:	Up to 4.3° (50% Io).
Vertical divergence:	Up to 4.3° (50% Io).
Power supply:	Up to 15W.
LED average life:	More than 100.000 hours.

Electronic control

Flash rhythms:	256 (6 nos. user selectable).
Circuit:	Microprocessor controlled.
Settings:	By microswitches or PC.
Input voltage:	From 9 to 36V d.c.
Day/night threshold:	Adjustable between 10 and 400 lux.
Power supply:	Individual for each LED.
Automatic & programmable luminous intensity reduction at night.	
Reverse-polarity, short-circuit, over-temperature and transient over-voltage protections.	

Materials and environment

Enclosure:	Marine aluminium, with polyurethane finishing.
Lens cover:	Circular, high-resistance glass.
Watertightness degree:	IP 67.
Humidity resistance:	100%. Pressure-compensation valve to avoid condensation.
Temperature range:	From -30° to 70°C.
Fixings:	3 - 4 nos. M10 bolts in a 200mm diameter.
All internal components are assembled on a base plate.	
Easy adjustment and levelling.	

MRL	PEAK INTENSITIES (Cd)				
	Power	Divergence	White ■	Green ■	Red ■
MRL 17	3W	1.7°	117,000	71,000	64,000
MRL 20	3W	2.0°	143,000	---	---
MRL 43	15W	4.3°	130,000	91,300	82,000



MEDITERRÁNEO SEÑALES MARÍTIMAS, S.L.L.
mesemar@mesemar.com • www.mesemar.com

